

7180DB ETHERNET ANYTHING I/O MANUAL

Version 1.19

This page intentionally not blank

Table of Contents

GENERAL	1
DESCRIPTION	1
HARDWARE CONFIGURATION	2
GENERAL	2
BREAKOUT POWER OPTION	2
5V I/O TOLERANCE	2
PRECONFIG PULL-UP ENABLE	3
IP ADDRESS SELECTION	3
CONNECTORS	4
CONNECTOR LOCATIONS AND DEFAULT JUMPER POSITIONS	4
7180DB I/O CONNECTOR PIN-OUT	5
POWER CONNECTOR PIN-OUT	9
JTAG CONNECTOR PIN-OUT	9
OPERATION	10
FPGA	10
FPGA PINOUT	10
IP ADDRESS SELECTION	10
HOST COMMUNICATION	10
UDP	10
LBP16	10
WINDOWS ARP ISSUES	10
CONFIGURATION	11
FALLBACK	11
DUAL EEPROMS	11
EEPROM LAYOUT	12
BITFILE FORMAT	14

Table of Contents

OPERATION	10
MESAFLASH	14
SETTING EEPROM IP ADDRESS	14
FREE EEPROM SPACE	15
FALLBACK INDICATION	15
FAILURE TO CONFIGURE	15
CLOCK SIGNALS	15
LEDS	16
PULLUP RESISTORS	16
I/O LEVELS	16
STARTUP I/O VOLTAGE	16
INTERFACE CABLES	17

Table of Contents

SUPPLIED CONFIGURATIONS	18
HOSTMOT2	18
7I76X4	18
7I76_7I74x2	18
G540X4	18
7I77X4	18
7I77_7I76x2	18
7I77_7I74x2	19
7I74X4	19
7I78X4	19
PROB_RFX4	19
PIN FILES	19
REFERENCE INFORMATION	20
LBP16	
LBP16 COMMANDS	20
INFO AREA	21
INFO AREA MEMSIZES FORMAT	21
INFO AREA MEMRANGES FORMAT	22
INFO AREA ACCESS	23
7I80DB SUPPORTED MEMORY SPACES	24
SPACE0: HOSTMOT2 REGISTERS	24
SPACE1: ETHERNET CHIP ACCESS	26
SPACE2: ETHERNET EEPROM CHIP ACCESS	26
ETHERNET EEPROM LAYOUT	27
SPACE3: FPGA FLASH EEPROM CHIP ACCESS	29
FLASH MEMORY REGISTERS	29
SPACE4: LBP TIMER/UTIL REGISTERS	32
SPACE6: LBP STATUS/CONTROL REGISTERS	33
MEMORY SPACE 6 LAYOUT	33
ERROR REGISTER FORMAT	34
SPACE7: LBP READ ONLY INFORMATION	35
MEMORY SPACE 7 LAYOUT	35
ELBPCOM	36
SPECIFICATIONS	37
CARD DRAWING	38

GENERAL

DESCRIPTION

The MESA 7180DB is a low cost, general purpose, FPGA based programmable I/O card with 100 BaseT Ethernet host connection. The 7180DB that uses standard parallel port pinouts and connectors for compatibility with most parallel port interfaced motion control / CNC breakout cards/ multi axis step motor drives, allowing a motion control performance boost while retaining a reliable real time Ethernet interface. Unlike the parallel port that the 7180DB replaces, each I/O bit has individually programmable direction and function.

The 7180DB has a simplified UDP host data transfer systems that allows operation in real time and compatibility with standard networks. Dual FPGA configuration EEPROMs allow simple recovery from programming mistakes. The 7180DB provides 68 I/O bits (17 per connector) All I/O bits are 5V tolerant and have pullup resistors. A power source option allows the 7180DB to supply 5V power to breakout boards if desired. This 5V power is protected by a PTC.

Firmware modules are provided for hardware step generation, quadrature encoder counting, PWM generation, digital I/O, Smart Serial remote I/O, BISS, SSI, SPI, UART interfaces and more. Configurations are available that are compatible with common breakout cards and multi axis step motor drives like the Gecko G540. All motion control firmware is open source and easily modified to support new functions or different mixes of functions.

There are currently six 7180DB compatible breakout cards available from Mesa, the 7174 through 7178 and 7185. The 7176 is a step/dir oriented breakout with 5 axis of buffered step/dir outputs, one spindle encoder input, one isolated 0-10V analog spindle speed plus isolated direction and enable outputs, one RS-422 expansion port, 32 isolated 5-32V inputs and 16 isolated 5-32V 300 mA outputs. The 7177 is a analog servo interface with 6 encoder inputs, 6 analog +-10V outputs, one RS-422 expansion port, 32 isolated 5-32V inputs, and 16 isolated 5-32V 300 mA outputs. The 7180DB supports four breakout cards so for example a 20 Axis step/dir configuration or 24 axis analog servo configuration is possible with a single 7180DB and four Mesa breakout cards.

HARDWARE CONFIGURATION

GENERAL

Hardware setup jumper positions assume that the 7I80DB card is oriented in an upright position, that is, with the Ethernet connector towards the left and the I/O connectors towards the right.

CONNECTOR 5V POWER

The 7I80DB has the option to supply 5V power from the to the breakout board. This option is used by all Mesa breakout boards to simplify wiring. The option uses 4 parallel cable signals that are normally used as grounds for supplying 5V to the remote breakout board (DB25 pins 22,23,24 and 25). These pins are AC bypassed on both the 7I80DB and Mesa breakout cards so do not compromise AC signal integrity. The 5V power option is individually selectable for each of the four I/O connectors. The breakout 5V power is protected by per connector PTC devices so will not cause damage to the 7I80DB or system if accidentally shorted. This option should only be enabled for Mesa breakout boards or boards specifically wired to accept 5V power on DB25 pins 22 through 25. When the option is disabled DB25 pins 22 through 25 are grounded. Jumper W6 controls the power option on J2, W7 on J3, W9 on J4, and W10 on J5.

JUMPER	POS	FUNCTION
W6,W7,W9,W10	RIGHT	BREAKOUT POWER ENABLED
W6,W7,W9,W10	LEFT	BREAKOUT POWER DISABLED (<i>DEFAULT</i>)

5V I/O TOLERANCE

The FPGA used on the 7I80DB has a 4V absolute maximum input voltage specification. To allow interfacing with 5V inputs, the 7I80DB has bus switches on all I/O pins. The bus switches work by turning off when the input voltage exceeds a preset threshold. *The 5V I/O tolerance option is the default and should normally be left enabled.*

For high speed applications where only 3.3V maximum signals are present and overshoot clamping is desired, the 5V I/O tolerance option can be disabled. W4 controls the 5V I/O tolerance option. When W4 is on the default UP position, 5V tolerance mode is enabled. When W4 is in the DOWN position, 5V tolerance mode is disabled. Note that W4 controls 5V tolerance on all I/O connectors.

PULLUP VOLTAGE

Jumper W5 selects the I/O connector pull-up resistor voltage, When W5 is in the UP position the 4.7K I/O pullup resistor common is connected to 5V, When W5 is in the down position, The 4.7K I/O pullup resistor common is connected to 3.3V.

HARDWARE CONFIGURATION

PRECONFIG PULLUP ENABLE

The Xilinx FPGA on the 7I80DB has the option of having weak pull-ups on all I/O pins at power-up or reset. To enable the built-in pull-ups, (the default condition) jumper W3 should be placed in the UP position. To disable the internal pull-ups, W3 should be in the DOWN position. It is suggested the W3 be left in the UP position.

IP ADDRESS SELECTION

The 7I80DB has three options for selecting its IP address. These options are selected by Jumpers W1 and W2.

W1	W2	IP ADDRESS
DOWN	DOWN	FIXED 192.168.1.121 (DEFAULT)
DOWN	UP	FIXED FROM EEPROM
UP	DOWN	BOOTP
UP	UP	INVALID

FPGA FLASH SELECT

To make recovery from FPGA configuration errors easier, there are two FPGA configuration flash memories on the 7I80DB card. Jumper W8 selects between the two flash memories. That is, if one flash memory is inadvertently corrupted, the other one can be used to boot the 7I80DB, allowing the corrupted flash memory to be re-written. It is suggested that W8 be left in the UP position (primary flash memory) for normal operation, and only changed to the DOWN position (secondary flash memory) if configuration fails. Once rebooted via a power cycle, jumper W8 should be promptly restored to the UP position to allow the primary flash memory to be re-written.

W8	MEMORY
UP	PRIMARY (NORMAL OPERATION)
DOWN	SECONDARY (BACKUP)

CONNECTORS

CONNECTOR LOCATIONS AND DEFAULT JUMPER POSITIONS

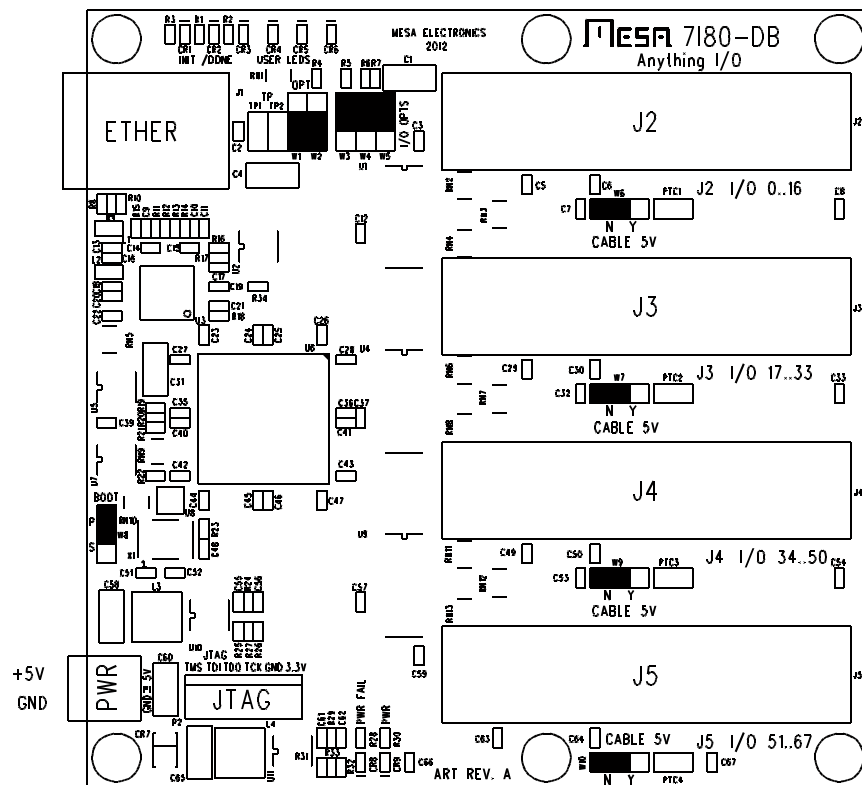

CONNECTORS

I/O CONNECTORS

The 7180DB has 4 I/O connectors, J2 through J5 please see the 7180DBIO.PIN file on the 7180DB distribution disk. 7180DB IO connector pinouts are as follows:

J2 FIRST I/O CONNECTOR PINOUT

DB25 PIN	FUNCTION	DB25 PIN	FUNCTION
1	IO0	14	IO1
2	IO2	15	IO3
3	IO4	16	IO5
4	IO6	17	IO7
5	IO8	18	GND
6	IO9	19	GND
7	IO10	20	GND
8	IO11	21	GND
9	IO12	22	GND or 5V
10	IO13	23	GND or 5V
11	IO14	24	GND or 5V
12	IO15	25	GND or 5V
13	IO16		

CONNECTORS

I/O CONNECTORS

J3 SECOND I/O CONNECTOR PINOUT

DB25 PIN	FUNCTION	DB25 PIN	FUNCTION
1	IO17	14	IO18
2	IO19	15	IO20
3	IO21	16	IO22
4	IO23	17	IO24
5	IO25	18	GND
6	IO26	19	GND
7	IO27	20	GND
8	IO28	21	GND
9	IO29	22	GND or 5V
10	IO30	23	GND or 5V
11	IO31	24	GND or 5V
12	IO32	25	GND or 5V
13	IO33		

CONNECTORS

I/O CONNECTORS

J4 THIRD I/O CONNECTOR PINOUT

DB25 PIN	FUNCTION	DB25 PIN	FUNCTION
1	IO34	14	IO35
2	IO36	15	IO37
3	IO38	16	IO39
4	IO40	17	IO41
5	IO42	18	GND
6	IO43	19	GND
7	IO44	20	GND
8	IO45	21	GND
9	IO46	22	GND or 5V
10	IO47	23	GND or 5V
11	IO48	24	GND or 5V
12	IO49	25	GND or 5V
13	IO50		

CONNECTORS

I/O CONNECTORS

J5 FOURTH I/O CONNECTOR PINOUT

DB25 PIN	FUNCTION	DB25 PIN	FUNCTION
1	IO51	14	IO52
2	IO53	15	IO54
3	IO55	16	IO56
4	IO57	17	IO58
5	IO59	18	GND
6	IO60	19	GND
7	IO61	20	GND
8	IO62	21	GND
9	IO63	22	GND or 5V
10	IO64	23	GND or 5V
11	IO65	24	GND or 5V
12	IO66	25	GND or 5V
13	IO67		

CONNECTORS

POWER CONNECTOR PINOUT

P1 is the 7180DBs power connector. P1 is a 3.5MM plug-in screw terminal block. P1 pinout is as follows:

PIN	FUNCTION	
1	+5V	TOP, SQUARE PAD
2	GND	BOTTOM, ROUND PAD

JTAG CONNECTOR PINOUT

P2 is a JTAG programming connector. This is normally used only for debugging or if both EEPROM configurations have been corrupted. In case of corrupted EEPROM contents the EEPROM can be re-programmed using Xilinx's Impact tool.

P2 JTAG CONNECTOR PINOUT

PIN	FUNCTION
1	TMS
2	TDI
3	TDO
4	TCK
5	GND
6	+3.3V

OPERATION

FPGA

The 7I80DB use a Xilinx Spartan6 FPGA in a 256 ball BGA package: XC6SLX16-FBGA256 or XC6SLX25-FBGA256 depending on 7I80DB model.

IP ADDRESS SELECTION

Initial communication with the 7I80DB requires knowing its IP address. The 7I80DB has 3 IP address options: Default, EEPROM, and Bootp, selected by jumpers W1 and W2. Default IP address is always 192.168.1.121. The EEPROM IP address is set by writing Ethernet EEPROM locations 0x20 and 0X22. BootP allows the 7I80DB address to be set by a DHCP/ BootP server. If BootP is chosen, the 7I80 will retry BootP requests at a ~1 Hz rate if the BootP server does not respond.

HOST COMMUNICATION

The 7I80DB standard firmware is designed for low overhead real time communication with a host controller so implements a very simple set of IPV4 operations. These operations include ARP reply, ICMP echo reply, and UDP packet receive/send for host data communications. UDP is used so that the 7I80DB can be used on a standard network with standard tools for non-real time applications. No fragmentation is allowed so maximum packet size is 1500 bytes.

UDP

All 7I80DB data communication is done via UDP packets. The 7I80DB socket number for UDP data communication is 27181. Read data is routed to the requesters port number. Under UDP, a simple register access protocol is used. This protocol is called LBP16.

LBP16

LBP16 allows read and write access to up to eight separate address spaces with different sizes and characteristics. Current firmware uses seven of these spaces. For efficiency, LBP16 allows access to blocks of registers at sequential increasing addresses. (Block transfers)

WINDOWS ARP ISSUES

Windows TCP stack has a characteristic that causes it to drop outgoing UDP packets when refreshing its ARP cache. Because of this you must either verify packet transmission via echoing data from the 7I80DB for every transaction (reading RXUDPCount is suggested) and retrying failed transactions, or alternatively, setting up a static entry for the 7I80DB in the ARP table. This is done with windows ARP command.

OPERATION

CONFIGURATION

The 7I80DB is configured at power up by a SPI FLASH memory. This flash memory is an 16M bit chip that has space for two configuration files. Since all Ethernet logic on the 7I80DB is in the FPGA, a problem with configuration means that Ethernet access will not be possible. For this reason there are two backup methods to recover from FPGA boot failures.

FALLBACK

The first backup system is called Fallback. The 7I80DB flash memory normally contains two configuration file images, A user image and a fallback image. If the primary user configuration is corrupted, the FPGA will load the fallback configuration so the flash memory image can be repaired remotely without having to resort to switching memories or JTAG programming.

DUAL EEPROMS

The second backup method relies on the fact that there are two flash memories on the 7I80DB card, selectable via jumper W8. If a configuration fails in such a way that it loads correctly (has a valid CRC) but does not work, the fallback configuration will not be invoked. To recover from this problem, the secondary flash can be selected by moving W8 to the DOWN position and using it to boot the FPGA (by cycling the power), restoring remote access and allowing the primary configuration to be repaired via Ethernet. The backup EEPROM is not write protected so if the primary EEPROM has been corrupted, you should always restore W8 to the UP position to avoid writing a bad configuration to both EEPROMS, necessitating a slow and awkward JTAG bootstrap.

OPERATION

EEPROM LAYOUT

The EEPROM used on the 7I80DB for configuration storage is the M25P16. The M25P16 is a 16 M bit (2 M byte) EEPROM with 32 64K byte sectors. Configuration files are stored on sector boundaries to allow individual configuration file erasing and updating. Standard EEPROM sector layout is as follows:

0x000000	BOOT BLOCK
0x010000	FALLBACK CONFIGURATION BLOCK 0
0x020000	FALLBACK CONFIGURATION BLOCK 1
0x030000	FALLBACK CONFIGURATION BLOCK 2
0x040000	FALLBACK CONFIGURATION BLOCK 3
0x050000	FALLBACK CONFIGURATION BLOCK 4
0x060000	FALLBACK CONFIGURATION BLOCK 5
0x070000	FALLBACK CONFIGURATION BLOCK 6
0x080000	FALLBACK CONFIGURATION BLOCK 7 / UNUSED 7I80DB-16
0x090000	FALLBACK CONFIGURATION BLOCK 8 / UNUSED 7I80DB-16
0x0A0000	FALLBACK CONFIGURATION BLOCK 9 / UNUSED 7I80DB-16
0x0B0000	FALLBACK CONFIGURATION BLOCK 10 / UNUSED 7I80DB-16
0x0C0000	FALLBACK CONFIGURATION BLOCK 11 / UNUSED 7I80DB-16
0x0D0000	FALLBACK CONFIGURATION BLOCK 12 / UNUSED 7I80DB-16
0x0E0000	UNUSED/FREE
0x0F0000	UNUSED/FREE

OPERATION

EEPROM LAYOUT

0x100000	USER CONFIGURATION BLOCK 0
0x110000	USER CONFIGURATION BLOCK 1
0x120000	USER CONFIGURATION BLOCK 2
0x130000	USER CONFIGURATION BLOCK 3
0x140000	USER CONFIGURATION BLOCK 4
0x150000	USER CONFIGURATION BLOCK 5
0x160000	USER CONFIGURATION BLOCK 6
0x170000	USER CONFIGURATION BLOCK 7 / UNUSED 7180DB-16
0x180000	USER CONFIGURATION BLOCK 8 / UNUSED 7180DB-16
0x190000	USER CONFIGURATION BLOCK 0 9 / UNUSED 7180DB-16
0x1A0000	USER CONFIGURATION BLOCK 0 10 / UNUSED 7180DB-16
0x1B0000	USER CONFIGURATION BLOCK 0 11 / UNUSED 7180DB-16
0x1C0000	USER CONFIGURATION BLOCK 0 12 / UNUSED 7180DB-16
0x1D0000	UNUSED/FREE
0x1E0000	UNUSED/FREE
0x1F0000	UNUSED/FREE

OPERATION

BITFILE FORMAT

The configuration utilities expect standard FPGA bitfiles without any multiboot features enabled. If multiboot FPGA files are loaded they will likely cause a configuration failure. In addition for fallback to work, the -g next_config_register_write:disable, -g reset_on_error:enable and -g CRC:enable bitgen options must be set.

MESAFLASH

Linux and Windows utility programs MESAFLASH are provided to write configuration files to the 7180DB EEPROM. These files depend on a simple SPI interface built into both the standard user FPGA bitfiles and the fallback bitfile. *The MESAFLASH utilities expect standard FPGA bitfiles without any multiboot features enabled. If multiboot FPGA files are loaded they will likely cause a configuration failure.*

If mesaflash is run with a -help command line argument it will print usage information.

The following examples assume the target 7180DB is using the ROM IP address of 192.168.1.121.

```
mesaflash --device 7i80 --write FPGAFILE.BIT
```

Writes a standard bitfile FPGAFILE.BIT to the user area of the EEPROM.

```
mesaflash --device 7i80 --verify FPGAFILE.BIT
```

Verifies the user EEPROM configuration against the bit file FPGAFILE.BIT.

```
mesaflash --device 7i80 --fallback --write FALLBACK.BIT
```

Writes the fallback EEPROM configuration to the fallback area of the EEPROM. In addition if the bootblock is not present in block 0 of the EEPROM, it re-writes the bootblock.

SETTING EEPROM IP ADDRESS

MESAFLASH can also write the EEPROM IP address of the 7180DB:

```
MESAFLASH --device 7i80 --set ip=192.168.0.100
```

The above examples assume the 7180 has its default ROM IP address (192.168.1.121). If the 7180 is using another IP address, this must be specified on the command line with a -addr XX.XX.XX.XX command line argument.

OPERATION

FREE FLASH MEMORY SPACE

Five 64K byte blocks of flash memory space are free when both user and fallback configurations are installed on the 7180DB-25. Seventeen 64K byte blocks are free on the 7180DB-16. It is suggested that only the last three blocks, 0x1D0000 through 0x1F0000 in the user area, be used for FPGA application flash storage.

FALLBACK INDICATION

Mesa's supplied fallback configurations blink the red INIT LED on the top right hand side of the card if the primary configuration fails and the fallback configuration loaded successfully. If this happens it means the user configuration is corrupted or not a proper configuration for the 7180DBs FPGA. This can be fixed by running the configuration utility and re-writing the user configuration.

FAILURE TO CONFIGURE

The 7180DB should configure its FPGA within a fraction of a second of power application. If the FPGA card fails to configure, the red /DONE LED CR2 will remain illuminated. If this happens the secondary EEPROM boot should be used. If booting from the secondary EEPROM fails, the 7180DBs EEPROMs must be re-programmed via the JTAG connector or (faster) JTAG FPGA load followed by Ethernet EEPROM update.

CLOCK SIGNALS

The 7180DB has a single 50 MHz clock signal from an on card crystal oscillator. The clock can be multiplied and divided by the FPGA's clock generator block to generate a wide range of internal clock signals. The 50 MHz clock is also used to generate the 25MHz clock for the Ethernet interface chip.

OPERATION

LEDS

The 7180DB has 4 FPGA driven user LEDs (User 0 through User 3 = Green), and 2 FPGA driven status LEDs (red). The user LEDs can be used for any purpose, and can be helpful as a simple debugging feature. A low output signal from the FPGA lights the LED. See the 7180DBIO.PIN file for FPGA pin locations of the LED signals. The status LEDs reflect the state of the FPGA's DONE, and /INIT pins. The /DONE LED lights until the FPGA is configured at power-up. The /INIT LED lights when the power on reset is asserted, when there has been a CRC error during configuration. When using Mesas configurations, the /INIT LED blinks when the fallback configuration has been loaded.

In addition to the FPGA driven LEDs, there are two power supply status LEDs on the bottom edge of the 7180DB card. There are the PWRFAIL and PWR LEDs. The PWRFAIL LED is illuminated if the locally regulated 1.2V or 3.3V power rails are out of specification. The PWR LED is illuminated when 3.3V is present.

PULLUP RESISTORS

All I/O pins are provided with pull-up resistors to allow connection to open drain, open collector, or OPTO devices. These resistors have a value of 4.7K so have a maximum pull-up current of ~1.07 mA (5V pull-up) or ~.7 mA (3.3V pull-up).

IO LEVELS

The Xilinx FPGAs used on the 7180DB have programmable I/O levels for interfacing with different logic families. The 7180DB does not support use of the I/O standards that require input reference voltages. All standard Mesa configurations use LVTTTL levels.

Note that even though the 7180DB can tolerate 5V signal inputs, its outputs will not swing to 5V. The outputs are push pull CMOS that will drive to the output supply rail of 3.3V. This is sufficient for TTL compatibility but may cause problems with some types of loads. For example when driving an LED that has its anode connected to 5V, in such devices as OPTO isolators and I/O module rack SSRs, the 3.3V high level may not completely turn the LED off. To avoid this problem, either drive loads that are ground referred, Use 3.3V as the VCC for VCC referred loads, or use open drain mode.

STARTUP I/O VOLTAGE

After power-up or system reset and before the the FPGA is configured, the pull-up resistors will pull all I/O signals to a high level. If the FPGA is used for motion control or controlling devices that could present a hazard when enabled, external circuitry should be designed so that this initial state (high) results in a safe condition.

OPERATION

INTERFACE CABLES

Mesa daughtercards use a male to male DB25 cable to interface to the 7I80DB. For noise immunity and signal fidelity it is suggested that only IEEE-1284 rated cables be used. IEEE-1284 rated cables have a twisted pair shield wire for each signal wire and an overall shield terminated in the metal connector shell. This results in much better performance than flat or NON-IEEE-1284 parallel port cables. For short connections of less than 3 feet, flat cables can be used. No other type of cable should be used.

Mesa can supply IEEE-1284 cables tested with the 7I80DB / daughtercard combination in 3, 6, and 10 foot lengths.

BREAKOUT POWER OPTION

When used with Mesa breakout/daughter cards, the 7I80DB can supply up to 1A of 5V power to each of the daughter cards. This option is disabled by default to avoid possible damage to standard breakout boards, so must be specifically enabled for Mesa daughtercards. If you use this option you must verify that the interface cable does not tie the eight parallel port ground wires together as some cheap printer cables do. Mesa supplied IEEE-1284 cables are the best option for Mesa daughter cards and are guaranteed to work with the power option. Flat cables will work as well but have poorer noise immunity and signal fidelity.

PLUG AND GO KITS

Motion control kits with pre-programmed 7I80DB, interface cable, and daughtercard(s) are available to simplify system integration.

SUPPLIED CONFIGURATIONS

HOSTMOT2

All supplied configurations are part of the HostMot2 motion control firmware set. All HostMot2 firmware is open source and easily extendible to support new interfaces or different sets of interfaces embedded in one configuration. For detailed register level information on Hostmot2 firmware modules, see the regmap file in the hostmot2 source code directory.

7I76X4

7I76X4 is a configuration intended to work with the 7I76 five axis step/dir daughtercard. It will support four 7I76 daughtercards, one on each of the 7I80DBs I/O connectors. The configuration includes twenty hardware step generators, four encoder inputs and eight Smart Serial interfaces, a watchdog timer and GPIO.

7I76_7I74x2

7I76_7I74x2 is a configuration for two 7I76 five axis step/dir daughtercards on J2 and J3 and two 7I74 eight channel RS-422 interface on J4 and J5. The 7I74 are configured with eight Smart Serial channels.

G540X4

G540X4 is a configuration intended to work with four Gecko G540 four axis step motor drives. It includes sixteen hardware step generators, four PWM generators, eight GPIO outputs, sixteen GPIO inputs, four charge pump drivers and a watchdog timer.

7I77X4

7I77X4 is a configuration intended to work with the 7I77 six axis analog servo daughtercard. It will support four 7I77 daughtercards. It includes twenty-four encoder inputs, twelve smart serial interfaces (eight used locally on the 7I77s and four fed through for additional remotes), a watchdog timer and GPIO.

7I77_7I76x2

7I77_7I76 is a configuration intended to work with two 7I77 six axis analog servo daughtercards on J2 and J3 and two 7I76 daughtercards on J4 and J5.

SUPPLIED CONFIGURATIONS

7177_7174x2

7174_7177x2 is a configuration intended to work with two 7177 six axis analog servo daughtercards on J2 and J3 and two 7174 eight channel RS-422 interface daughtercards on J4 and J5. It includes twelve encoder inputs, 22 smart serial interfaces (four used on the 7177 for 48 bit isolated field I/O and analog out) , a watchdog timer and GPIO.

7174X4

7174X4 is a configuration intended to work with four 7174 RS-422 daughter cards. It includes thirty-two smart serial interfaces allowing real time control of up to 1536 digital I/O points, a watchdog timer and GPIO.

7178X4

7178X4 is a configuration intended to work with the 7178 four axis step/dir daughtercard. It will support four 7178 daughtercards, one on each of the 7180DBs I/O connectors. The configuration includes sixteen hardware step generators, four PWM generators, four encoder inputs and four Smart Serial interfaces, a watchdog timer and GPIO.

PROB_RFX4

The PROB_RFX4 configuration is a step/dir configuration intended to work with most common parallel port breakouts. Four breakouts are supported, one on each of the 7180DBs I/O connectors. The configuration includes sixteen hardware step generators, four encoders with index, four PWM generators , a watchdog timer and GPIO.

PIN FILES

Each of the configurations has an associated file with file name extension .pin that describes the FPGA functions included in the configuration and the I/O pinout. These are plain text files that can be printed or viewed with any text editor.

REFERENCE INFORMATION

LBP16

LBP16 COMMANDS

LBP16 is a simple remote register access protocol to allow efficient register access over the Ethernet link. All LBP16 commands are 16 bits in length and have the following structure:

15	14	13	12	11	10	9	8	7	6	5	4	3	2	1	0
W	A	C	M	M	M	S	S	I	N	N	N	N	N	N	N

- W Is the write bit (1 means write, 0 means read)
- A Is the includes Address bit. If this is '1' the command is followed by a 16 bit address and the address pointer is loaded with this address. if this is 0 the current address pointer for the memory space is used. Each memory space has its own address pointer.
- C Indicates if memory space itself (C='0') or associated info area for the memory will be accessed (C= '1')
- M Is the 3 bit memory space specifier 000b through 111b
- S Is the transfer element size specifier (00b = 8 bits, 01b = 16 bits 10b = 32 bits and 11b = 64 bits)
- I Is the Increment address bit. if this is '1' the address pointer is incremented by the element transfer size (in bytes) after every transfer ('0' is useful for FIFO transfers)
- N Is the transfer count in units of the selected size. 1 through 127. A transfer count of 0 is an error.

LBP16 read commands are followed by the 16 bit address (if the A bit is set). LBP16 Write commands are followed by the address (if bit A is set) and the data to be written. LBP16 Addresses are always byte addresses. LBP data and addresses are little endian so must be sent LSB first.

REFERENCE INFORMATION

LBP16

INFO AREA

There are eight possible memory spaces in LBP16. Each memory space has an associated read only info area. The first entry has a cookie to verify correct access. The next two entries in the info area are the MemSizes word and the MemRanges word. Only 16 bit read access is allowed to the info area.

0000	COOKIE = 0X5A0N WHERE N = ADDRESS SPACE 0..7
0002	MEMSIZES
0004	MEMRANGES
0006	ADDRESS POINTER
0008	SPACENAME 0,1
000A	SPACENAME 2,3
000C	SPACENAME 4,5
000E	SPACENAME 6,7

INFO AREA MEMSIZES FORMAT

15	14	13	12	11	10	9	8	7	6	5	4	3	2	1	0
W	T	T	T	T	T	T	T	X	X	X	X	A	A	A	A

W Memory space is Writeable

T Is type: 01 = Register, 02 = Memory, 0E = EEPROM, 0F = Flash

A Is access types (bit 0 = 8 bit, bit 1 = 16 bit etc)so for example 0x06 means 16 bit and 32 bit operations allowed

REFERENCE INFORMATION

LBP16

INFO AREA MEMRANGES FORMAT

15	14	13	12	11	10	9	8	7	6	5	4	3	2	1	0
E	E	E	E	E	P	P	P	P	P	S	S	S	S	S	S

E Is erase block size

P Is Page size

S Ps address range

Ranges are 2^E , 2^P , 2^S . E and P are 0 for non-flash memory

REFERENCE INFORMATION

LBP16

INFO_AREA ACCESS

As discussed above, all memory spaces have an associated information area that describes the memory space. Information area data is all 16 bits and read-only. The hex command examples below are written in LSB first order for convenience. In the hex command examples, the NN is the count/increment field of the LBP16 command and the LLHH is the low and high bytes of the address.

Ispace 0 read with address	NN61LLHH	HostMot2 space
Ispace 0 read	NN21	
Ispace 1 read with address	NN65LLHH	Ethernet chip space
Ispace 1 read	NN25	
Ispace 2 read with address	NN69LLHH	Ethernet EEPROM space
Ispace 2 read	NN29	
Ispace 3 read with address	NN6DLLHH	FPGA flash space
Ispace 3 read	NN2D	
Ispace 6 read with address	NN79LLHH	LBP16 R/W space
Ispace 6 read	NN39	
Ispace 7 read with address	NN7DLLHH	LBP16 R/O space
Ispace 7 read	NN3D	

REFERENCE INFORMATION

LBP16

7180DB SUPPORTED MEMORY SPACES

The 7180DB firmware supports 6 address spaces. These will be described individually with example hexadecimal commands. The hex command examples below are written in LSB first order for convenience. In the hex command examples, the NN is the count/increment field of the LBP16 command and the LLHH is the low and high bytes of the address.

SPACE 0: HOSTMOT2 REGISTERS

This address space is the most important as it gives access to the FPGA I/O. This is a 64K byte address range space with 32 bit R/W access.

Space 0 read with address	NN42LLHH
Space 0 write with address	NNC2LLHH
Space 0 read	NN02
Space 0 write	NN82

REFERENCE INFORMATION

LBP16

SPACE 0: HOSTMOT2 REGISTERS

Example: read first 5 entries in hostmot2 IDROM:

85420004

85 ; 85 == NN = 5 | Inc bit (0x80) so address is incremented after each access
42 ; Read from space 0 with address included after command
00 ; LSB of address (IDROM starts at 0x0400)
04 ; MSB of address (IDROM starts at 0x0400)

Example: write 4 GPIO ports starting at 0x1000:

84C20010AAAAAAAABBBBBBBBCCCCCCCCDDDDDDDD

84 ; 84 == NN = 4 | Inc bit so address is incremented after each access
C2 ; Write to space 0 with address included after command
00 ; LSB of address (GPIO starts at 0x1000)
10 ; MSB of address (GPIO starts at 0x1000)
AAAAAAAA ; 32 bit data for GPIO port 0 at 0x1000
BBBBBBBB ; 32 bit data for GPIO port 0 at 0x1004
CCCCCCCC ; 32 bit data for GPIO port 0 at 0x1008
DDDDDDDD ; 32 bit data for GPIO port 0 at 0x100C

Note like all LBP16 data, write data is LS byte first

REFERENCE INFORMATION

LBP16

SPACE 1: ETHERNET CHIP ACCESS

Space 1 allows access to the KSZ8851-16 registers for debug purposes. All accesses are 16 bit.

Space 1 read with address NN45LLHH

Space 1 write with address NNC5LLHH

Space 1 read NN05

Space 1 write NN85

Example: read Ethernet chip CIDER register: 0145C000

01 ; = NN = read 1 16 bit value

45 ; read space 1 with address included

C0 ; LSB of CIDER address

00 ; MSB of CIDER address

SPACE 2: ETHERNET EEPROM CHIP ACCESS

This space is used to store the Ethernet MAC address, card name, and EEPROM settable IP address. The Ethernet EEPROM space is accessed as 16 bit data. The first 0x20 bytes are read only and the remaining 0x60 bytes are read/write.

Space 2 read with address NN49LLHH

Space 2 write with address NNC9LLHH

Space 2 read NN09

Space 2 write NN89

REFERENCE INFORMATION

LBP16

SPACE2: ETHERNET EEPROM CHIP ACCESS

Writes and erases require that the EEPROMWEna be set to 5A02. *Note that EEPROMWEna is cleared at the end of every LPB packet so the write EEPROMWEna command needs to be prepended to all EEPROM write and erase packets.* For EEPROM write operations a LBP16 read operation should follow the write(s) for host synchronization.

Example: write EEPROM IP address with 192.168.0.32 (C0:A8:0:20 in hex)

01D91A00025A

Enable EEPROM area writes

82C920002000A8C0

Write 2 words to 0020 : C0A80020 (with inc). Note this must be in the same packet and the EEPROMWEna write

ETHERNET EEPROM LAYOUT

ADDRESS	DATA
---------	------

0000	Reserved RO
------	-------------

0002	MAC address LS Word RO
------	------------------------

0004	MAC address Mid Word RO
------	-------------------------

0006	MAC address MS Word RO
------	------------------------

0008	Reserved RO
------	-------------

000A	Reserved RO
------	-------------

000C	Reserved RO
------	-------------

000E	Unused RO
------	-----------

REFERENCE INFORMATION

LBP16

ETHERNET EEPROM LAYOUT

ADDRESS	DATA
0010	CardNameChar-0,1 RO
0012	CardNameChar-2,3 RO
0014	CardNameChar-4,5 RO
0016	CardNameChar-6,7 RO
0018	CardNameChar-8,9 RO
001A	CardNameChar-10,11 RO
001C	CardNameChar-12,13 RO
001E	CardNameChar-14,15 RO
0020	EEPROM IP address LS word RW
0022	EEPROM IP address MS word RW
0024	EEPROM Netmask LS word RW (V16 and > firmware)
0026	EEPROM Netmask MS word RW (V16 and > firmware)
0028	DEBUG LED Mode (LS bit determines HostMot2 (0) or debug(1)) RW
002A	Reserved RW
002C	Reserved RW
002E	Reserved RW
0030..007E	Unused RW

REFERENCE INFORMATION

LBP16

SPACE 3: FPGA FLASH EEPROM CHIP ACCESS

Space 3 allows access to the FPGAs configuration flash memory. All flash memory access is 32 bit. Flash memory access is different from other memory spaces in that it is done indirectly via a 32 bit address pointer and 32 bit data port.

Space 3 read with address NN4ELLHH

Space 3 write with address NNCELLHHDDDDDDDD

Space 3 read NN0E

Space 3 write NN8E

FLASH MEMORY REGISTERS

Flash memory spaces have only 4 accessible registers:

ADDRESS	DATA	
0000	FL_ADDR	32 bit flash address register
0004	FL_DATA	32 bit flash data register
0008	FL_ID	32 bit read only flash ID register
000C	SEC_ERASE	32 bit write only sector erase register

Unlike other memory spaces, flash memory space is accessed indirectly by writing the address register (FL_ADDR) and then reading or writing the data (FL_DATA). The flash byte address is automatically incremented by 4 each data access.

Note that reads can read all of flash memory with consecutive read operations but write operations can only write a flash page worth of data before the page write must be started. Also unless you are doing partial page writes, page write should always start on a page boundary.

The page write is started by writing the flash address, reading the flash address, reading flash data, reading flash ID or issuing a erase sector command. For host synchronization, a read operation should follow every sector erase or page write.

REFERENCE INFORMATION

LBP16

SPACE 3: FPGA FLASH EEPROM CHIP ACCESS

Example: read 1024 bytes (0100h doublewords) of flash space at address 00123456:

01CE000056341200	Write FL_ADDR (0000) with pointer (0x00123456)
404E0400	Issue read command (FL_DATA = 0004) With count of 0x40 double words (256 bytes). Note do not use LBP16 increment bit! Flash address always autoincremented
400E	Next 0x40 doublewords = 256 bytes
400E	Next 0x40 doublewords = 256 bytes
400E	Next 0x40 doublewords = 256 bytes

Note that this is close to the maximum reads allowed in a single LBP packet (~1450 bytes)

Writes and erases require that the EEPROMWEna be set to 5A03. *Note that EEPROMWEna is cleared at the end of every LPB packet so the write EEPROMWEna command needs to be prepended to all flash write and erase packets. The following is written on separate lines for clarity but must all be in one packet for correct operation.*

Example: Write a 256 byte page of flash memory starting at 0xC000:

01D91A00035A	Write EEPROMWEna with 0x5A03
01CE000000C00000	Write flash address
40CE0400	Issue write flash data command with count
12345678	Doubleword 0
ABCD8888	Doubleword 1
...	
FFFFFFFF	Doubleword 63 (= 256 bytes)
014E0000	Read new address to commit write and so some data is returned for host synchronization (so host waits for write to complete)

REFERENCE INFORMATION

LBP16

SPACE 3: FPGA FLASH EEPROM CHIP ACCESS

Example: Erase flash sector 0x00010000:

01D91A00035A	Write EEPROMWEna with 0x5A03
01CE00000000100	Write flash address with 0x 00010000
01CE0C0000000000	Write sector erase command (with dummy 32 bit data = 0)
014E0000	Read flash address for host synchronization (this will echo the address <u>after</u> the sector is erased)

REFERENCE INFORMATION

LBP16

SPACE 4 LBP TIMER/UTILITY AREA

Address space 4 is for read/write access to LBP specific timing registers. All memory space 4 access is 16 bit.

Space 4 read with address	NN51LLHH
Space 4 write with address	NND1LLHHDDDD
Space 4 read	NN11
Space 4 write	NN91DDDD

MEMORY SPACE 4 LAYOUT:

ADDRESS	DATA
0000	uSTimeStampReg
0002	WaituSReg
0004	HM2Timeout
0006	WaitForHM2RefTime
0008	WaitForHM2Timer1
000A	WaitForHM2Timer2
000C	WaitForHM2Timer3
000E	WaitForHM2Timer4
0010..001E	Scratch registers for any use

The uSTimeStamp register reads the free running hardware microsecond timer. It is useful for timing internal 7I80 operations. Writes to the uSTimeStamp register are a no-op. The WaituS register delays processing for the specified number of microseconds when written, (0 to 65535 uS) reads return the last wait time written. The HM2TimeOut register sets the timeout value for all WaitForHM2 times (0 to 65536 uS).

All the WaitForHM2Timer registers wait for the rising edge of the specified timer or reference output when read or written, write data is don't care, and reads return the wait time in uS. The HM2TimeOut register places an upper bound on how long the WaitForHM2 operations will wait. HM2Timeouts set the HM2Timeout error bit in the error register.

REFERENCE INFORMATION

LBP16

SPACE 6 LBP STATUS/CONTROL AREA

Address space 6 is for read/write access to LBP specific control, status, and error registers. All memory space 6 access is 16 bit. The RXUDPCount and TXUDPCount can be used as sequence numbers to verify packet reception and transmission.

Space 6 read with address	NN59LLHH
Space 6 write with address	NND9LLHHDDDD
Space 6 read	NN19
Space 6 write	NN99DDDD

MEMORY SPACE 6 LAYOUT:

ADDRESS	DATA
0000	ErrorReg
0002	LBPParseErrors
0004	LBPMemErrors
0006	LBPWriteErrors
0008	RXPktCount
000A	RXUDPCount
000C	RXBadCount
000E	TXPktCount
00010	TXUDPCount
00012	TXBadCount

REFERENCE INFORMATION

LBP16

MEMORY SPACE 6 LAYOUT:

ADDRESS	DATA	
0014	LEDMode	If LSb is 0, LEDs are "owned" by HostMot2, otherwise LEDs are local debug LEDs
0016	DebugLEDPtr	What variable in space 6 local debug LEDs show (default is RXPktCount).
0018	Scratch	Can be used for sequence numbers
001A	EEPROMWEna	Must be set to 5A0N to enable EEPROM or flash writes or erases (N is memory space of EEPROM or flash) Note that this is cleared at the end of every packet.
001C	LBPReset	Setting this to a non-zero value will do a full reset of the LBP16 firmware. The 7I80DB will read its IP address jumpers and re-assign its IP address. The 7I80DB will be unresponsive for as much as ½ of a second after this command.
001E	FPGAICAP	FPGA ICAP-16 register to allow remote FPGA reload and other low level FPGA access.

ERROR REGISTER FORMAT

BIT	ERROR
0	LBPParseError
1	LBPMemError
2	LBPWriteError
3	RXPacketErr
4	TXPacketErr
5	HM2TimeOutError
6..15	Reserved

REFERENCE INFORMATION

LBP16

SPACE 7: LBP READ ONLY AREA

Memory space 7 is used for read only card information. Memory space 7 is accessed as 16 bit data.

Space 7 read with address NN5DLLHH

Space 7 read NN1D

MEMORY SPACE 7 LAYOUT:

ADDRESS	DATA	
0000	CardNameChar-0,1	
0002	CardNameChar-2,3	
0004	CardNameChar-4,5	
0006	CardNameChar-6,7	
0008	CardNameChar-8,9	
000A	CardNameChar-10,11	
000C	CardNameChar-12,13	
000E	CardNameChar-14,15	
0010	LBPVersion	
0012	FirmwareVersion	
0014	Option Jumpers	
0016	Reserved	
0018	RecvStartTS	1 uSec timestamps
001A	RecvDoneTS	For performance monitoring
001C	SendStartTS	Send timestamps are
001E	SendDoneTS	from <i>previous</i> packet

REFERENCE INFORMATION

LBP16

ELBPCOM

ELBPCOM is a very simple demo program in Python (2.x) to allow simple checking of LBP16 host communication to the 7I80DB. ELBPCOM accepts hexadecimal LBP16 commands and data and returns hexadecimal results. Note that the timeout value will need to be increased to about 2 seconds to try flash sector erase commands.

```
import socket
s = socket.socket(socket.AF_INET, socket.SOCK_DGRAM, 0)
sip = "192.168.1.121"
sport = 27181
s.settimeout(.2)
while(2 >0):
    sdata = raw_input('>')
    sdata = sdata.decode('hex')
    s.sendto(sdata, (sip, sport))
    try:
        data, addr = s.recvfrom(1280)
        print('>'), data.encode('hex')
    except socket.timeout:
        print('No answer')
```

Sample run:

```
>01420001 ; read hostmot2 cookie at 0x100
> fecaaa55 ; 7I80DB returns 0x55AACAFE

>82492000 ; read EEPROM IP address at 0x0020
> 450a5863 ; 63:58:0A:45 = 99.88.10.69
; (for example)

>01D91A00025A82C920000100a8C0 ; write EEPROM IP address
; (at 0x0020) with
; C0:A8:0:1 = 192.168.0.1
```

REFERENCE

SPECIFICATIONS

POWER	MIN	MAX	NOTES:
5V POWER SUPPLY	4.5V	5.5V	P1 supplied 5V
5V POWER CONSUMPTION:	----	5A	Depends on FPGA configuration and external load
MAX 5V CURRENT TO I/O CONNS	---	1000 mA	Each (PTC Limit)
TEMPERATURE RANGE -C version	0 °C	+70 °C	
TEMPERATURE RANGE -I version	-40 °C	+85 °C	

REFERENCE INFORMATION

CARD DRAWING

